

## SA SELECTORIZED SERIES

## SA043 - MULTI PRESS



## PRODUCT OVERVIEW

The SA043 is a multifunctional selectorized strength machine specifically designed for comprehensive chest and shoulder training. It supports a variety of pressing and pec fly movements across multiple angles, effectively targeting the anterior deltoids, upper pectorals, and overall chest thickness and definition. Built with high-precision craftsmanship and equipped with a smooth pulley system, the machine ensures fluid, stable motion for safer and more efficient workouts.

Multiple grip positions are provided to support wide, narrow, horizontal, and vertical pressing paths, enabling versatile training of both the shoulders and chest. The 6-position adjustable starting arm allows customization based on user height and training posture. Its motion path is biomechanically optimized to align with the natural shoulder joint curve, enhancing comfort and muscle engagement.

The 3-position adjustable backrest and seat enable precise coordination between grip position and training posture, supporting a range of movements from incline presses to shoulder presses. An additional low-position cable handle is integrated for fly movements, further expanding training possibilities and maximizing the equipment's functional value.

# SPECIFICATIONS & KEY FEATURES

## Specifications

Dimension:	1628*1483*1768mm
Total Weight:	254kg
Weight Stack:	100kg
Max Weight Stack:	125kg

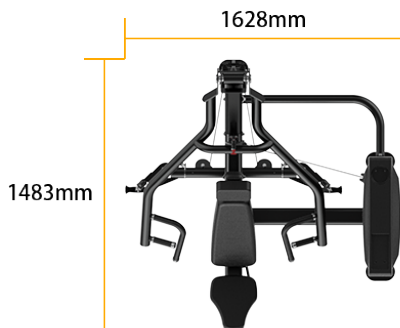
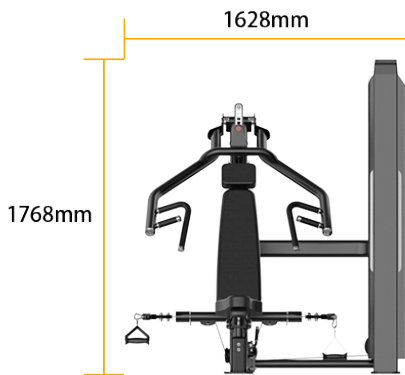

## Product Features



### Multifunctional Design

Supports a wide range of chest and shoulder exercises across various angles, maximizing space efficiency and training variety.

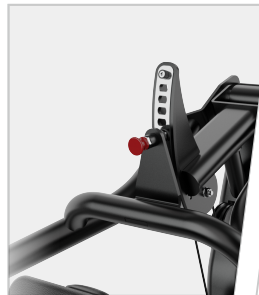

### 6-Position Starting Arm Adjustment

Accommodates different body types and exercise preferences, with motion paths aligned to muscle fiber orientation for natural, effective force output.



### 3-Level Adjustable Backrest and Seat

Ensures proper alignment of movement angle, body posture, and training objective for enhanced workout stability and effectiveness.



### Integrated Cable Fly Handle

Expands the machine's capabilities with more pec fly variations, adapting to different user needs and training goals.